

# PUREAIRO HEPA PRO 870



## PRE FILTER, HEPA / ACTIVATED CARBON FILTER

### PROVEN PERFORMANCE

- Buying a commercial indoor air scrubber with both a Pre-filter and HEPA/activated carbon filter will ensure that you remove both airborne particle and chemical pollutants.
- Surprisingly, this air scrubber also has built-in UV-C Light. UV-C light technology works with filters to enhance the elimination of airborne germs.
- Titanium Dioxide is activated by the UV-C light to decompose remaining odor molecules caused by smoking, cooking, and pets.
- The AlorAir PureAiro HEPA Pro 870 air scrubber, with it, is a bigger air intake than competitors' units intake. It has a 16-inch air inlet. It can produce 550 CFM airflow volumes at its peak, which virtually adsorbs all hazardous particles from the air.
- During restoration work and drying after water damage, the driving airflow can stir up particulates and particles adhering to the carpet or other materials. Then those dirty particles can be filtrated by the device with the clean, odor-free air.

### OTHER FEATURES

- Hour meter to monitor units usage duration.
- Filter change light indicates when HEPA /Activated carbon filter. needs to be changed.
- Daisy chain capability - link up to 3 units on 1 power outlet.
- Stackable, lightweight, and easily transportable.
- Made from rotomolded plastic for maximum durability.
- Both Inlet and outlet can be ducted.
- Suitable for use in homes, light industrial settings, schools, hospitality venues, and healthcare environments-wherever portable, efficient HEPA filtration is needed.

### How does the UV-C light works?

#### Sterilization Features

- UV-C: The germicidal UV light is effective in microbial control. Scientific research has proven that the most effective frequency for microbial destruction is between 200nm and 280nm, which is within the UV-C band therefore, as long as the nm wavelength of a germicidal lamp is within that range, the microorganisms will be destroyed effectively.

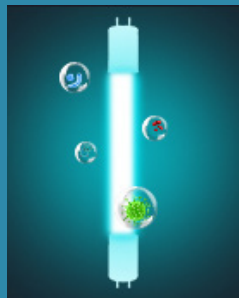

- UV-C light damages the bacteria at a cellular level; it destroys their DNA or RNA structure, so the bacteria can no longer reproduce. It is also effective at eliminating "superbugs", the type of pathogens that have developed a resistance to modern medicine and are hard to eliminate with chemical sprays. UV sanitizing wands have been tested and proven to eliminate 100% of several types of bacteria commonly found on surfaces within 5 seconds, and inactivate 90% of hardy spore-forming bacteria in 40 seconds. According to the research, a UV-C device is a reasonable alternative to using chemicals to disinfect surfaces.



RESTORATION



PROFESSIONAL



MOLD REMEDIATION

Specifications	PureAiro HEPA Pro 870
Power	2.5Amps, 115V, 60 HZ, Transparent Indicated Lighting Plug
Duct Sizes Intakes	16 in.
Duct Sizes Outlets	8 in.
Cord	23 ft Power Cord
Outlet	15A UL Rated GFCI Duplex Receptacle
Static Pressure	2.8 in. (H2O)
Sound Pressure Level	<65 dBA
Filters	Pre-filter and HEPA/activated carbon filter
Weight	37.4 lbs
Shipping Dim (LxWxH)	28.8 x 24.4 x 14.8 in
Airflow Range	270-550 CFM
Loading Quantity	20': 204 Sets; 40': 432 Sets; 40'HQ: 496 Sets

# PUREAIRO HEPA PRO 870



## PRE FILTER, HEPA / ACTIVATED CARBON FILTER

### APPLICATIONS

- **PureAiro HEPA Pro 870** is a versatile air scrubber and negative air machine that is a portable filtration system with UV-C light. It is equipped with a bigger air intake than most competitors units. It has a 14-inch air inlet for increased airflow efficiently. These filters efficiently remove particles from the air to help improve indoor air quality. That can effectively complete your water damage restoration tasks, mold remediation works, fire damage restoration, dust control, odor control, and sewage remediation.
- **Water Damage** In a standard Category 1 water damage situation, place the **PureAiro HEPA Pro 870** in the middle of the affected area. Air movers can stir up particles into the air. The **PureAiro HEPA Pro 870** can reduce particle levels by filtering the air in the restoration process.
- **Mold Remediation** in most cases required the affected area to be well sealed. Space sealing prevents the spread of mold spores and dust. Professionals with specialized remediation techniques use the **PureAiro HEPA Pro 870** to bring about a striking effect of air cleaning.
- Formally trained remediation professionals use the **PureAiro HEPA Pro 870** as a negative air machine without interruption for the duration of every remediation job. The **PureAiro HEPA Pro 870** can filter up to 99.95% of particles with 0.3 microns or larger size, such as mold spores and fungi.
- **Manifold Filters** Besides the standard Pre-filter, **PureAiro HEPA Pro 870** also equipped with a HEPA/activated carbon filter which can capture a wide variety of volatile organic compounds (VOCs), including soot, smoke, food odors, fumes from paint and paint thinners, sewer odors, and many other compounds. Individually wrapped filters with pellets ensure the maximum airflow and maximum contact while minimizing filter dust.



Applicable For Water Damage Restoration Tasks



Great For Mold Remediation Works

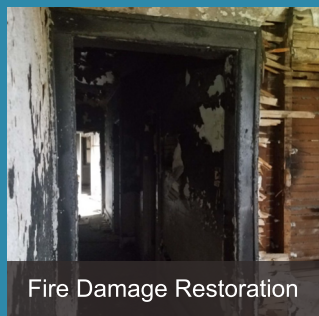

Fire Damage Restoration



Captures Dirt And Dust

Recommended use(s) of on-board duplex GFCI are shown.  
Note: Standard 115VAC electrical outlets.

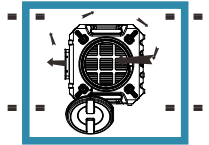

▲ As An Air Scrubber

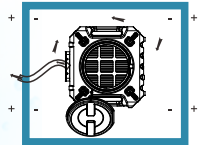

▲ As A Negative Air Machine

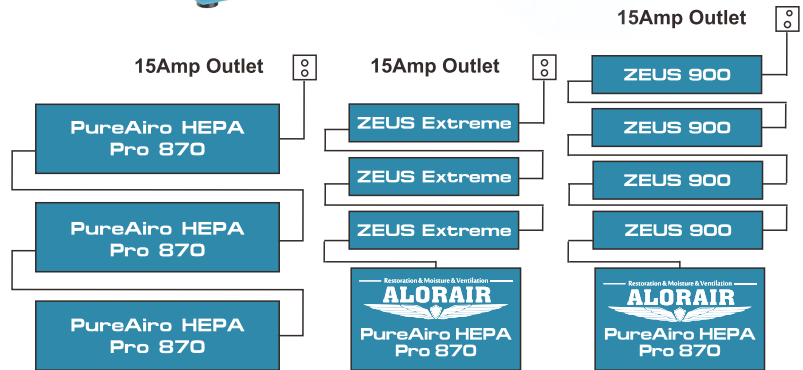

### CONTROL PANEL

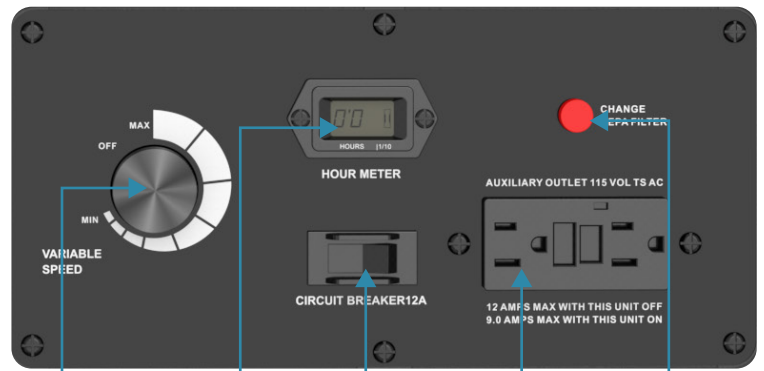

Variable speed control    Hour Meter    Circuit Breaker 12A    GFCI receptacles    Change HEPA Filter